

Japanese Devil - Model: Jun Maekawa, diagrams: Hugo Pereira

<http://hugo.pereira.free.fr>

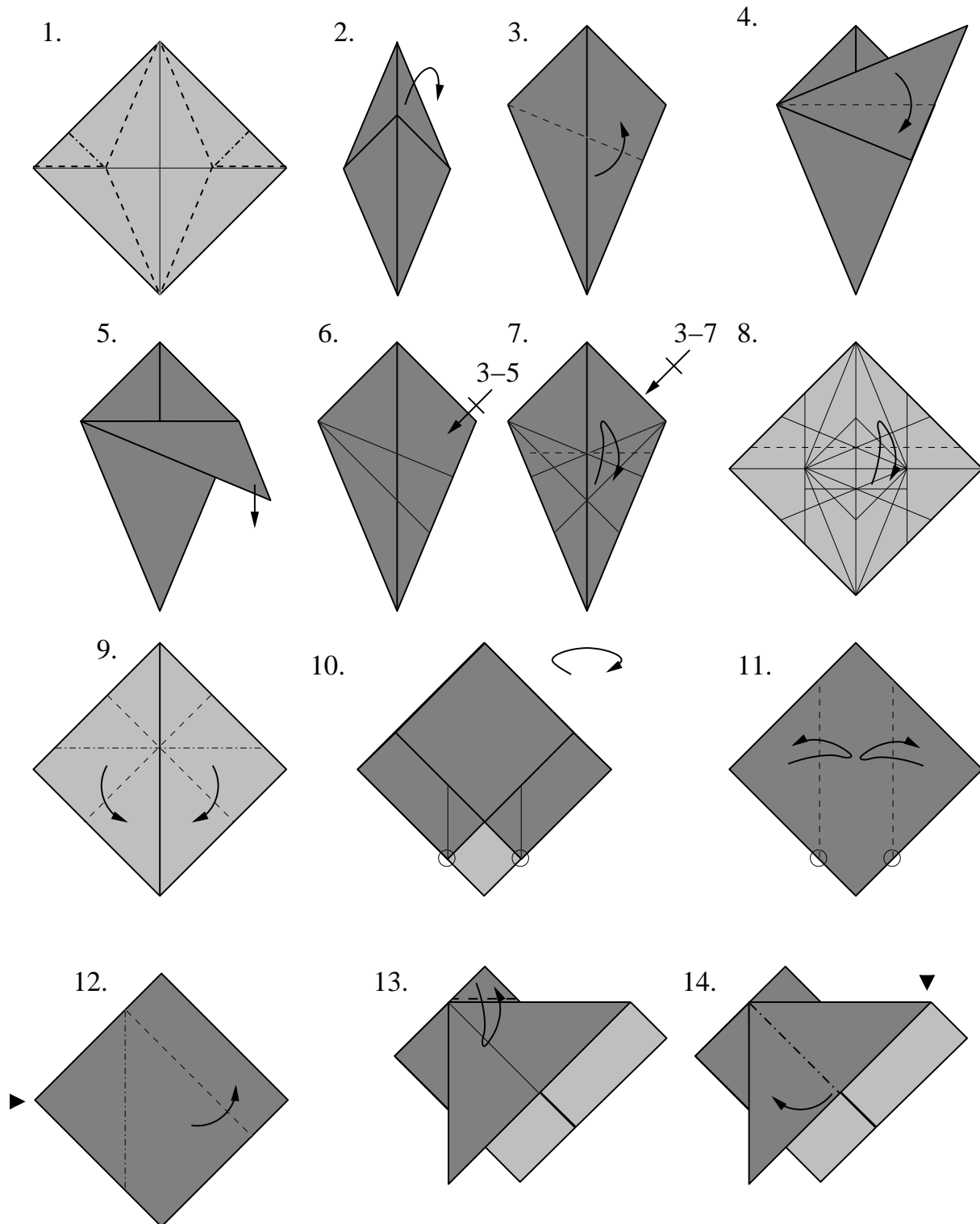

Japanese Devil - Model: Jun Maekawa, diagrams: Hugo Pereira

<http://hugo.pereira.free.fr>

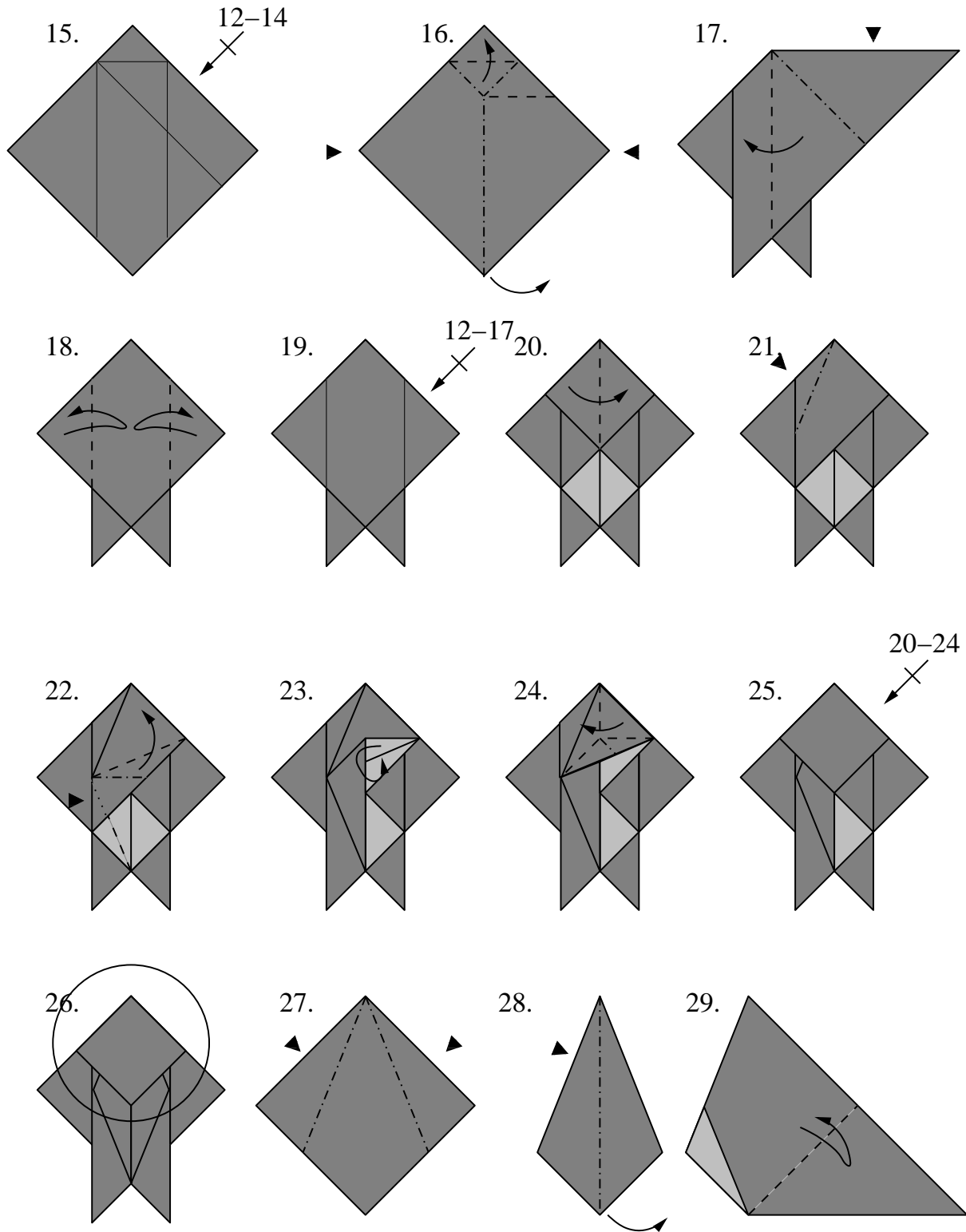

Japanese Devil - Model: Jun Maekawa, diagrams: Hugo Pereira

<http://hugo.pereira.free.fr>

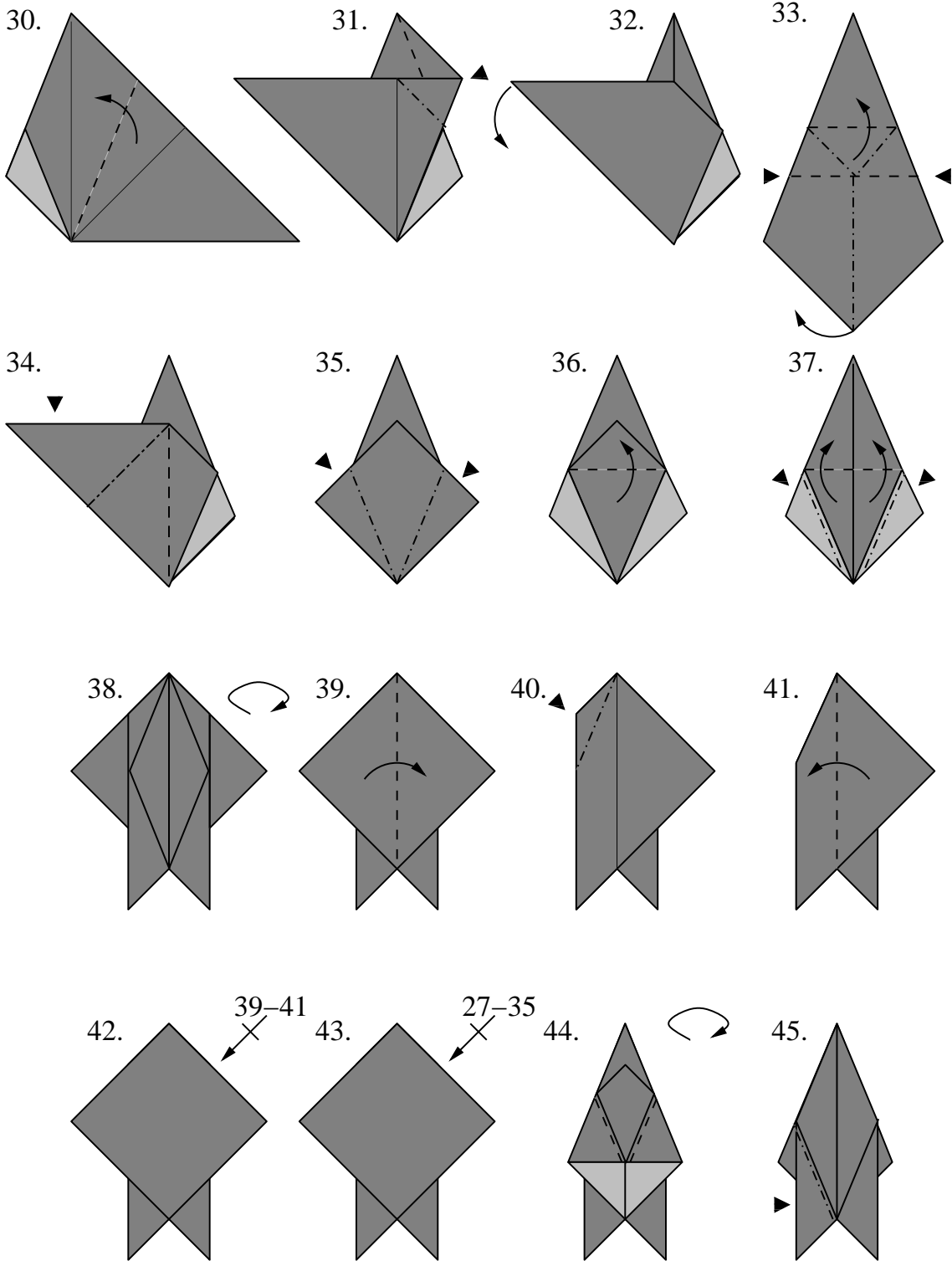

Japanese Devil - Model: Jun Maekawa, diagrams: Hugo Pereira

<http://hugo.pereira.free.fr>

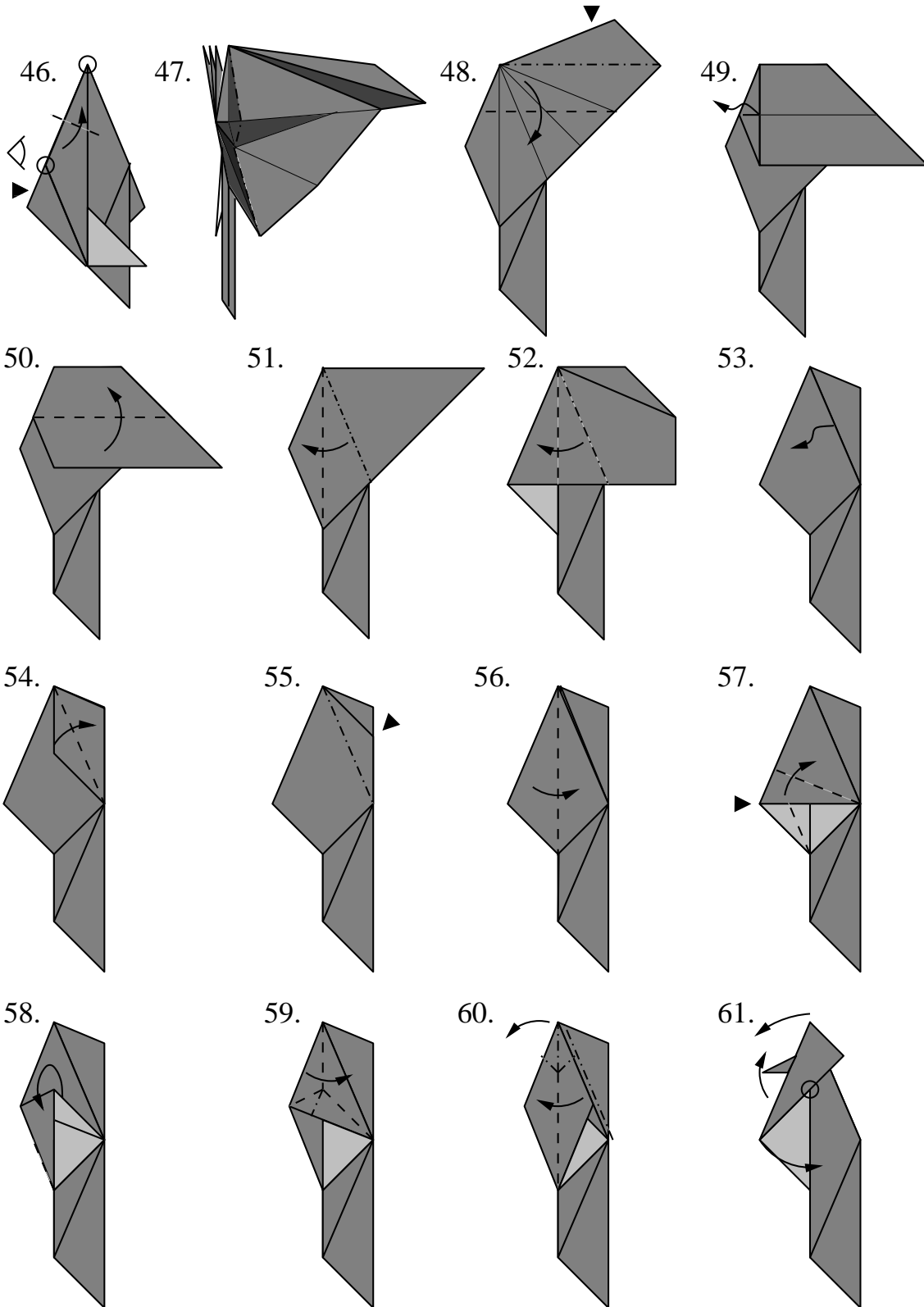

Japanese Devil - Model: Jun Maekawa, diagrams: Hugo Pereira

<http://hugo.pereira.free.fr>

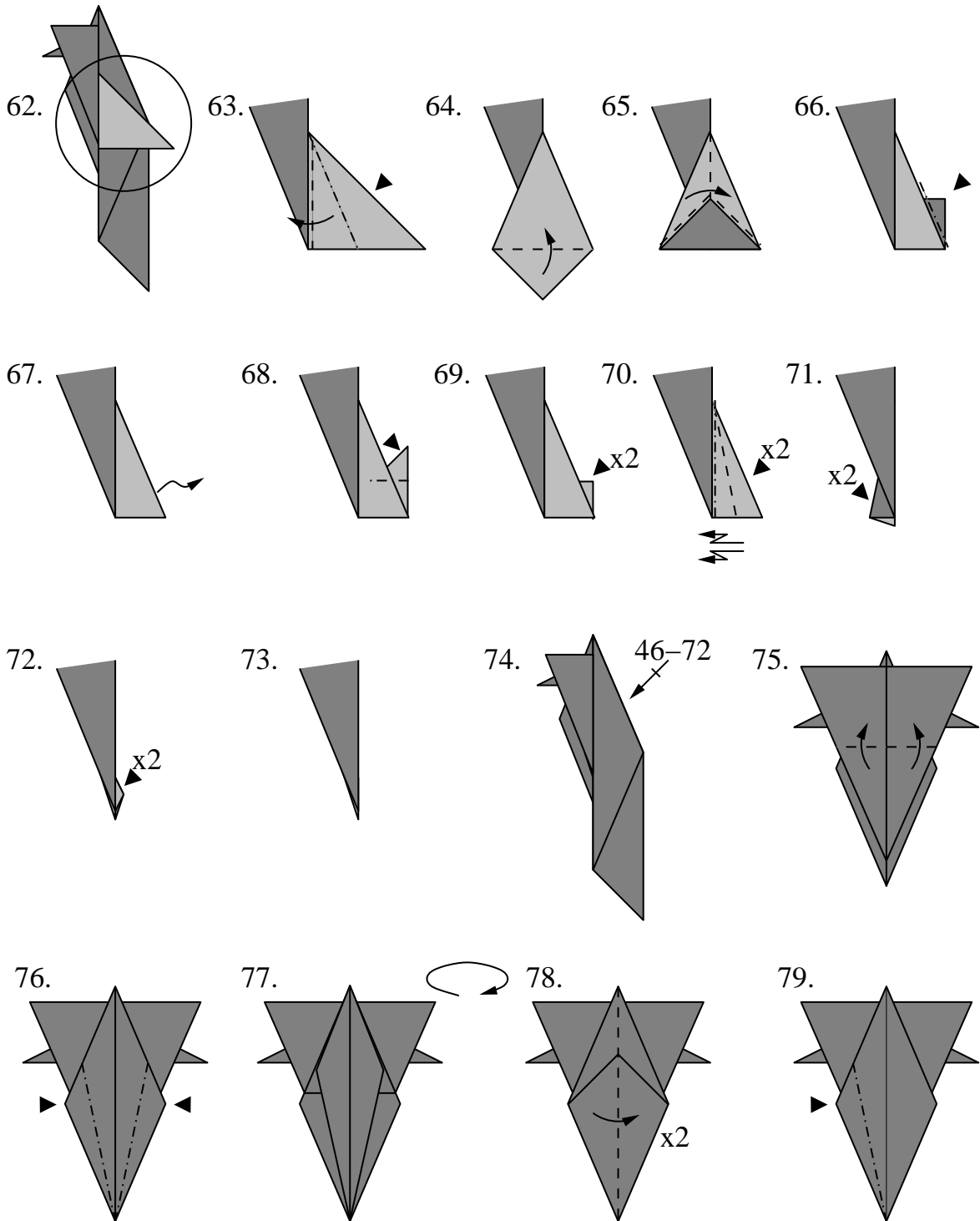

Japanese Devil - Model: Jun Maekawa, diagrams: Hugo Pereira

<http://hugo.pereira.free.fr>

80.

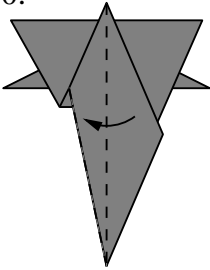

81.

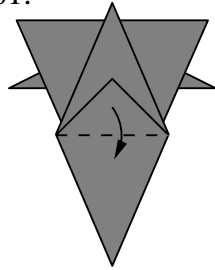

82.

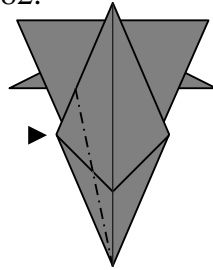

83.

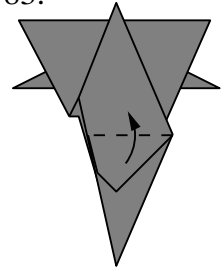

84.

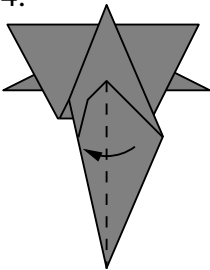

85.

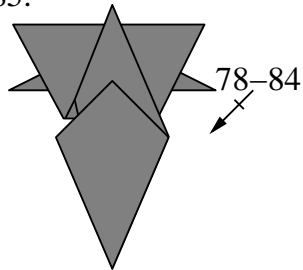

86.

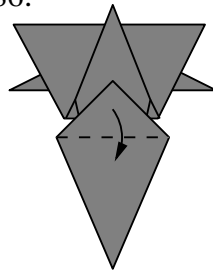

87.

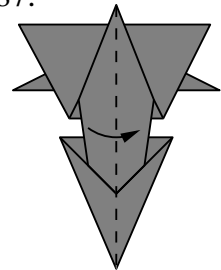

88.

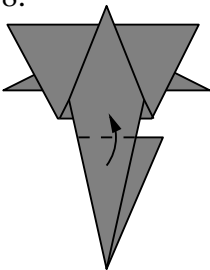

89.

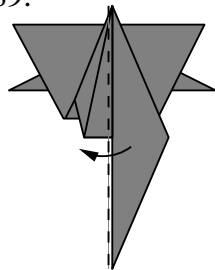

90.

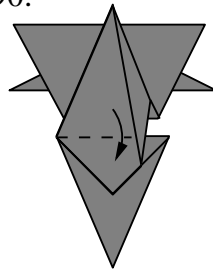

91.

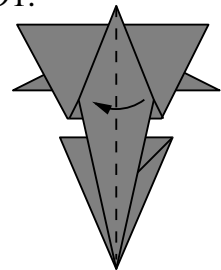

92.

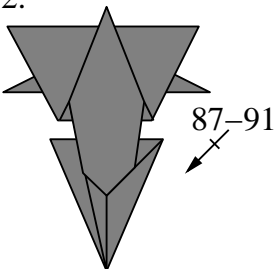

93.

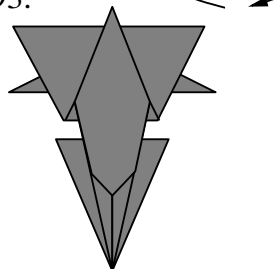

94.

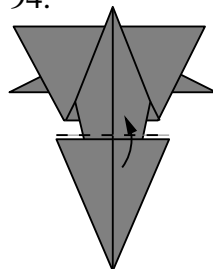

95.

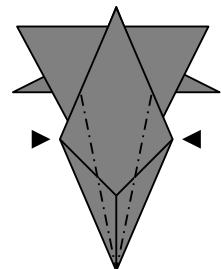

Japanese Devil - Model: Jun Maekawa, diagrams: Hugo Pereira

<http://hugo.pereira.free.fr>

96.

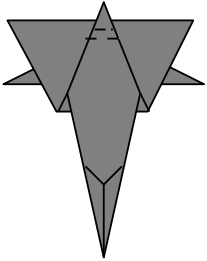

97.

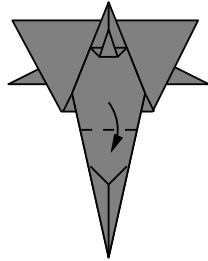

98.

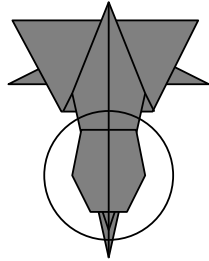

99.

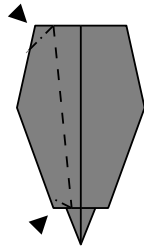

100.

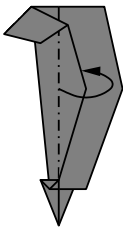

101.

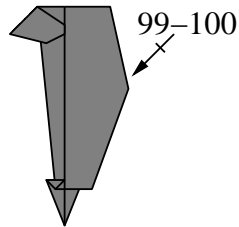

102.

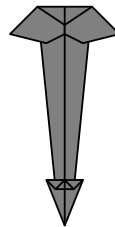

103.

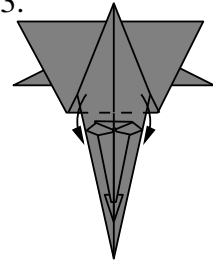

104.

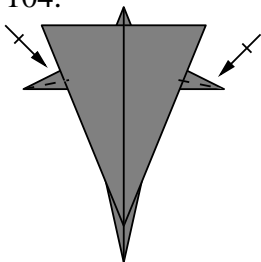

105.

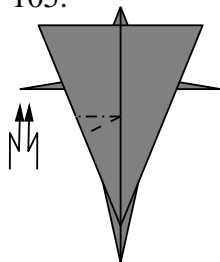

106.

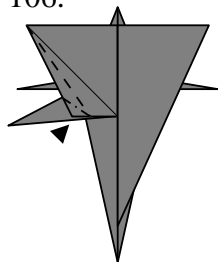

107.

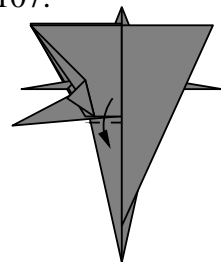

108.

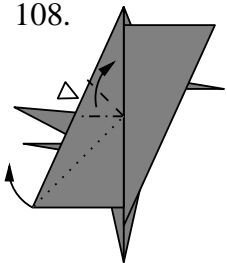

109.

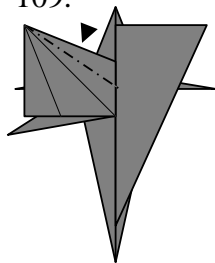

110.

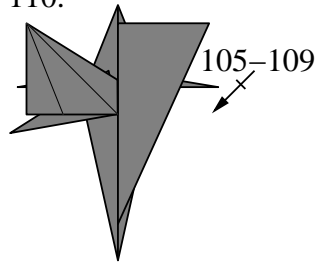

111.

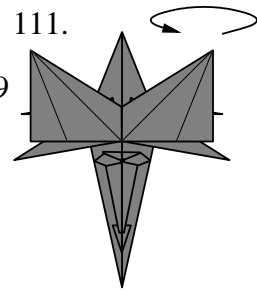

Japanese Devil - Model: Jun Maekawa, diagrams: Hugo Pereira

<http://hugo.pereira.free.fr>

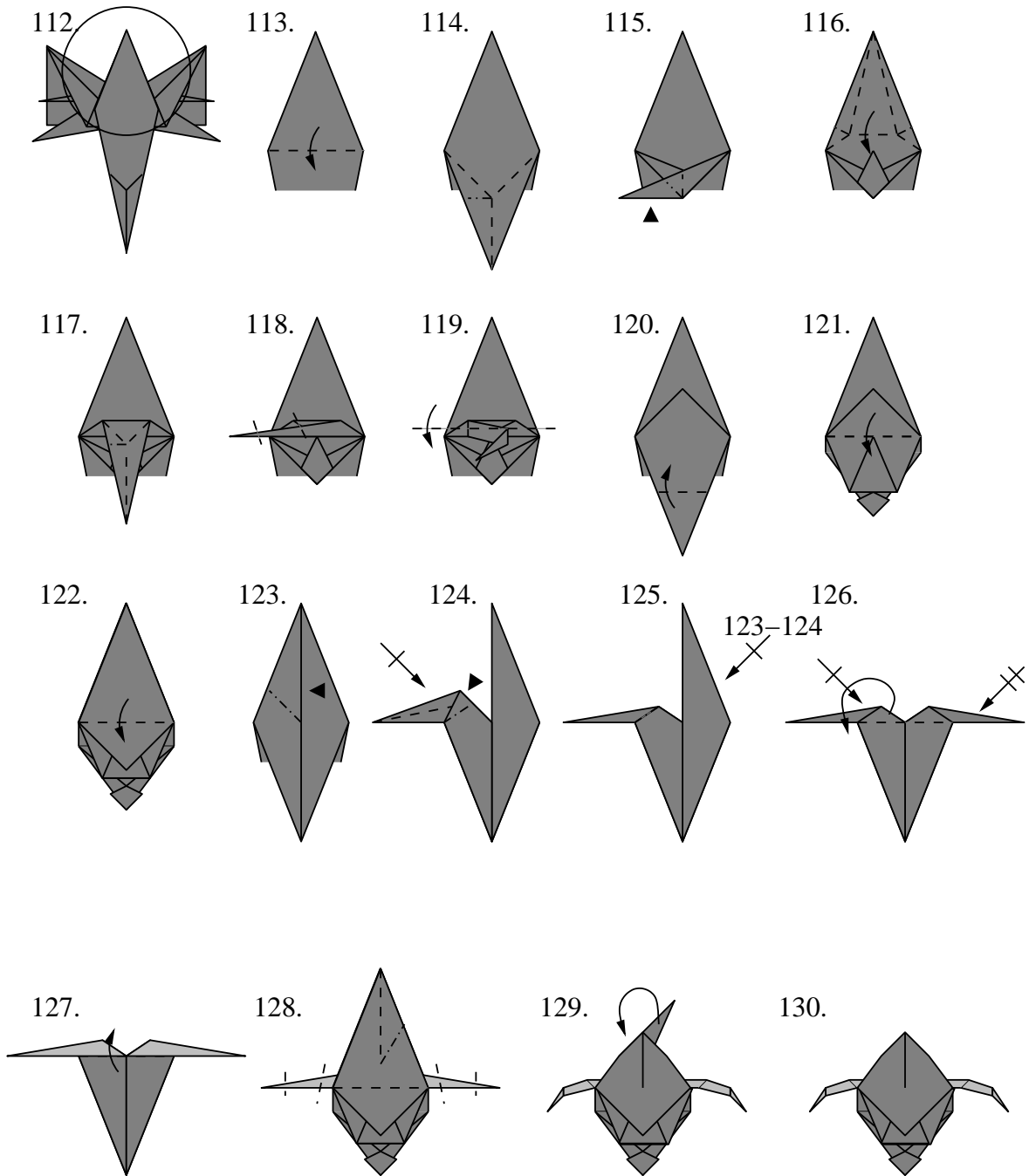

Japanese Devil - Model: Jun Maekawa, diagrams: Hugo Pereira

<http://hugo.pereira.free.fr>

131.

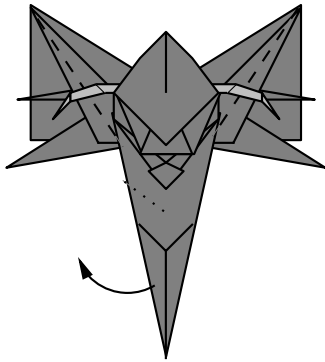

132.

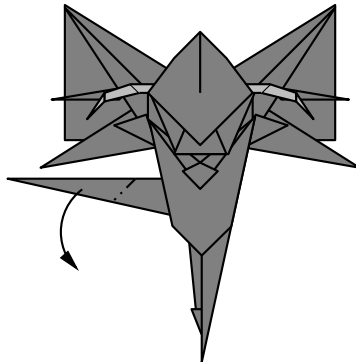

133.

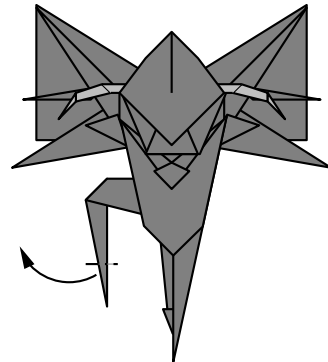

134.

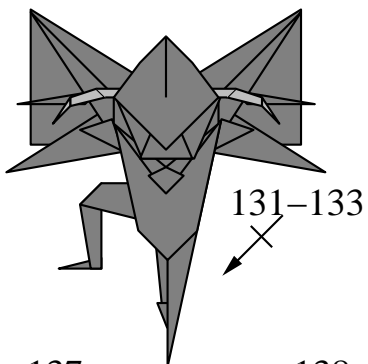

135.

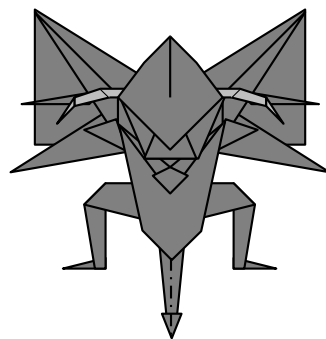

136.

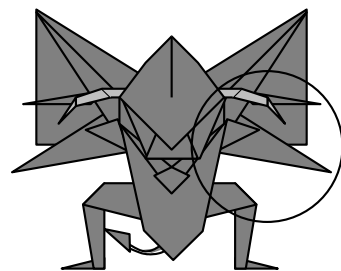

137.

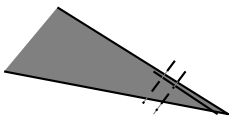

138.

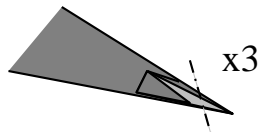

139.

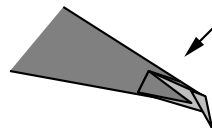

140.

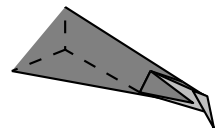

141.

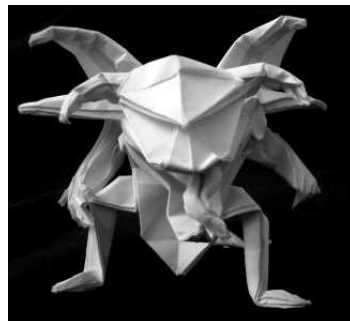

Comments

1. Start with a square with pre-creased diagonals. Rabbit ear on both sides.
2. Fold down the back flap.
3. Valley fold up perpendicular to the edge.
4. Valley fold down at angle bisector.
5. Unfold back to step 2.
6. Repeat steps 3 to 5 on the right side.
7. Repeat steps 3 to 7 in the back, and unfold the model entirely.
8. Fold and unfold along an existing crease.
9. Form a preliminary fold using the crease made at step 8.
10. Note the two corners and the vertical creases starting from them. Turn over.
11. Fold and unfold along the creases noted at step 10.
12. Squash fold along the crease made at step 10.
13. Fold and unfold the top triangle.
14. Unfold back to step 12.
15. Repeat steps 12 to 14 on the other side.
16. Collapse the front flap using existing creases.
17. Squash fold the front flap.
18. Fold and unfold on both sides so that the creases line up with the flaps immediately behind.
19. Repeat steps 12 to 17 on the front flap.
20. Fold one flap to the right.
21. Open sink the corner at angle bisector.
22. Swivel fold the front layer upwards.
23. Wrap one layer around.
24. Wrap one flap to the left, incorporating a reverse fold.
25. Repeat steps 20 to 24 on the right.
26. Next steps focus on the top square, front flap only.
27. Reverse fold on both sides.
28. Swivel fold the front flap to the right.

29. Fold and unfold perpendicular to the edge.
30. Valley fold at angle bisector.
31. Reverse fold at angle bisector.
32. Unfold back to step 28.
33. Collapse the front layer using existing creases.
34. Squash fold down the flap on the left.
35. Reverse fold on both sides.
36. Valley fold up the front flap.
37. Valley fold up one flap on both side, by adding reverse folds at angle bisector.
38. Full view. Turn over.
39. Valley fold one flap to the right.
40. Open sink at angle bisector.
41. Valley fold one flap to the left.
42. Repeat steps 38 to 40 on the right side.
43. Repeat steps 27 to 35 on the front flap.
44. Fold and unfold one layer along the sides of the front flap. Turn over.
45. Reverse fold one flap so that the crease lies along the front flap.
46. Fold point up so that it reaches the top point of the model. You must bring two flaps together and open the model from the middle.
47. Side view. Intermediate view of previous step. Include mountain folds along existing creases to flatten the model. The front flap will form the left wing assembly.
48. Swivel fold one layer down. You will have to release some hidden trapped paper behind the front flap, and flatten.
49. Pull out one layer from the inside. This is equivalent to undoing an open sink.
50. Valley fold one layer up.
51. Swivel fold to the left.
52. Swivel fold to the left.
53. Pull out one layer from the inside. This is equivalent to undoing an open sink.
54. Valley fold one flap to the right.
55. Open sink the flap.
56. There should now be two separate points at the top. Valley fold one flap to the right.

57. Swivel fold one layer along angle bisector.
58. Wrap one layer around.
59. Valley fold one layer to the right, including a reverse fold.
60. Swivel fold all layers to the left, adding a mountain fold where indicated and a reverse fold to the first top point, to form the left horn.
61. Rotate the left wing assembly counter-wise around the indicated point by adding swivel folds to the hidden layers and raise the left horn slightly by rearranging the hidden reverse folds.
62. The next few steps focus on the white triangle flap at the base of the left wing assembly. It will form the left hand.
63. Squash fold at angle bisector.
64. Valley fold the bottom triangle up.
65. Fold one flap to the right, adding a reverse fold along the edges of the dark triangle.
66. Reverse fold the small dark triangle.
67. Pull out some trapped paper.
68. Reverse fold one layer.
69. Reverse fold the two small white triangles.
70. Crimp the front and back layers together at angle bisector.
71. Reverse fold the excess two dark triangles.
72. Reverse fold again the excess two white triangles.
73. Completed hand. There should be 5 points at the tip of the assembly, which will form the fingers.
74. Repeat steps 46 to 72 on the right side.
75. Valley fold the front flap up as far as possible on both sides. The tip of the hand should reach the top corner.
76. Open sink along angle bisector on both sides. Note that there are some extra folds in the way at the top of the sink.
77. Turn over.
78. Valley fold two flaps to the right.
79. Open sink along angle bisector on both sides. Again, there are some extra folds in the way at the top of the sink.
80. Valley fold one flap to the left.
81. Valley fold the triangle down.

82. Open sink. Note that the fold on the small triangle does not reach the tip of the triangle.
83. Valley fold the front flap up.
84. Fold one flap to the left.
85. Repeat steps 78 to 84 on the right side. The next few steps focus on bringing the front flap to the back.
86. Valley fold down the front flap.
87. Valley fold one flap to the right.
88. Valley fold one flap up.
89. Valley fold one flap to the left.
90. Valley fold one flap down.
91. Valley fold one flap to the left.
92. Repeat steps 87 to 91 to the right.
93. Turn over.
94. Valley fold one flap up.
95. Open sink at angle bisector on both sides.
96. The top front flap will form the tail. Crimp the top of the front flap.
97. Valley fold front flap down.
98. The next few steps focus on the front flap only.
99. Valley fold one flap to the right, adding squash folds at the top and at the bottom. The bottom point lies at approximately $\frac{1}{3}$ from the side. Do not fold the small crimped triangle behind.
100. Mountain fold the excess paper behind. Tuck it behind one layer of paper.
101. Repeat steps 99 and 100 on the right side.
102. Completed tail.
103. Valley fold down the front layer on both sides.
104. Narrow the horns by adding reverse folds symmetrically to all constituting layers.
105. Crimp the front left layer to form the arm. (Note: for clarity, the tail assembly is not represented.)
106. Valley fold two layer to the right at angle bisector, adding a squash fold at the bottom.
107. Valley fold down the arm and wing assembly. Do not crease firmly.
108. Valley fold the assembly back up, adding a reverse fold to the first three layers and rotating the bottom flap behind.

109. Like so. Reverse fold three layers at angle bisector.
110. The left arm and wing are completed. Repeat steps 105 to 109 on the right side.
111. The back of the model is completed. Turn over.
112. The next few steps focus on the top layers. It will form the head.
113. Valley fold one flap down as far as you can.
114. Rabbit ear the bottom flap to the left.
115. Squash fold the front flap symmetrically. This will form the lower jaw.
116. Valley fold down one flap, adding reverse folds on both sides to narrow the flap. This will form the tongue.
117. Rabbit ear the narrow flap to the left.
118. Crimp the flap to shape the tongue.
119. Valley fold one flap down. Note that the model will not lie flat because of the flaps behind. This to give the head a 3D shape.
120. Valley fold the bottom flap up. This will form the upper jaw.
121. Valley fold one flap down. This will form the forehead and the eyes.
122. Valley fold one flap down.
123. Reverse fold the left flap at angle bisector. This will form the left horn.
124. Narrow the horn by adding reverse folds at angle bisector to the front and behind.
125. Repeat steps 123 and 124 on the right side.
126. Optional: wrap one layer of paper around. Repeat behind and to the right. This will change the color of the horns.
127. like so. Valley fold one flap up.
128. Shape the horns by adding reverse folds. Crimp the top layer to give a 3D shape to the forehead.
129. Mountain fold the excess paper behind.
130. Completed head.
131. Full view. Reverse fold the left leg starting as far up as you can.
132. Reverse fold down.
133. Reverse fold to the left, to form the foot.
134. Repeat steps 131 to 133 on the right leg.
135. Shape the tail by folding it in half and rounding it.
136. The last few steps focus on the right hand, to shape the fingers.

137. Crimp the front flap to form the thumb.
138. Outside reverse fold the next three flaps to form fingers and claws.
139. Crimp the last flap (approximately like in step 137) to form the little finger.
140. Finally narrow the arm and bring it towards the front of the model by adding a rabbit ear, and repeat steps 137 to 140 on the left arm.
141. Completed devil.